

Product Data Sheet

Metco SmartArc Advanced Electric Wire Arc Thermal Spray System

The Metco™ SmartArc is a state-of-the-art, advanced electric wire arc spray system for high productivity that produces repeatable coatings of unsurpassed quality.

A premium system, SmartArc has innovative engineering that ensures it will produce highly reliable electric wire arc spray coatings, while being cost-effective and having outstanding ease-of-use and serviceability.

With applications in a wide variety of industries, SmartArc is the answer for swift, cost-effective thermal spray coatings for wear protection, restoration of component dimension and corrosion protection. Some examples of applications where SmartArc produces excellent value are:

- Industrial rollers used in printing and textiles, paper and pulp production, embossing and steel manufacturing,
- Automotive mufflers and exhaust pipe seam welds,
- Aviation and aerospace components requiring bond coatings and machinable restoration coatings,
- Hydroelectric turbine parts for power generation,
- Aluminum extrusion mills,
- Tube mill weld seams.



SmartArc PPC Console and 350RU Power Supply (shown with optional Power Supply Truck)

When used with Oerlikon Metco's extensive portfolio of high quality wire arc materials, SmartArc delivers superior coatings, at high deposition rate, and with ease.

1 General Description

The high power capacity (400 A) allows SmartArc to deposit coatings from both hard and soft wires very quickly and economically. Hard wire coatings produced using the SmartArc system have excellent bond strength, high hardness, low porosity and are easily machined. When soft wires are used, exceptionally high coatings rates of up to 32 kg/h (70 lb/h) are possible.

SmartArc incorporates a leading-edge gun head design that delivers low-turbulence, nearly laminar air flow. This results in high deposition rates, very dense, low oxide coatings and a reduction in consumables and maintenance. Voltage measurement is at the gun for reliable coating results.

A unique feature of SmartArc is load-sharing; a patented motor control method that provides "push-pull" coordination of the wire feed stock. As a result, wire feed is very smooth, allowing wire conduit cables of up to 15 m (50 ft). This allows the SmartArc PPG gun to be mounted on a robot or other gun manipulation equipment for added precision and automation. When the gun "pull" motor, that acts as the master feed motor, needs assistance, SmartArc senses the load and has the console motor "push" harder to ensure highly consistent wire feed.

Truly automated, SmartArc incorporates rugged and reliable PLC (programmable logic control) computer technology for its advanced feature capability and provides diagnostics tests that are easily interpreted by the operator.



SmartArc PPG Wire Arc Spray Gun

Two gun models are available for the SmartArc system. The PPG gun (CE-conformant) is a machine-mount push-pull design. The PPGH hand-held model offers an optional gun handle that incorporates an integrated, system-wide E-stop and wire speed control, on the handle. (Not for sale in CE-conforming countries)

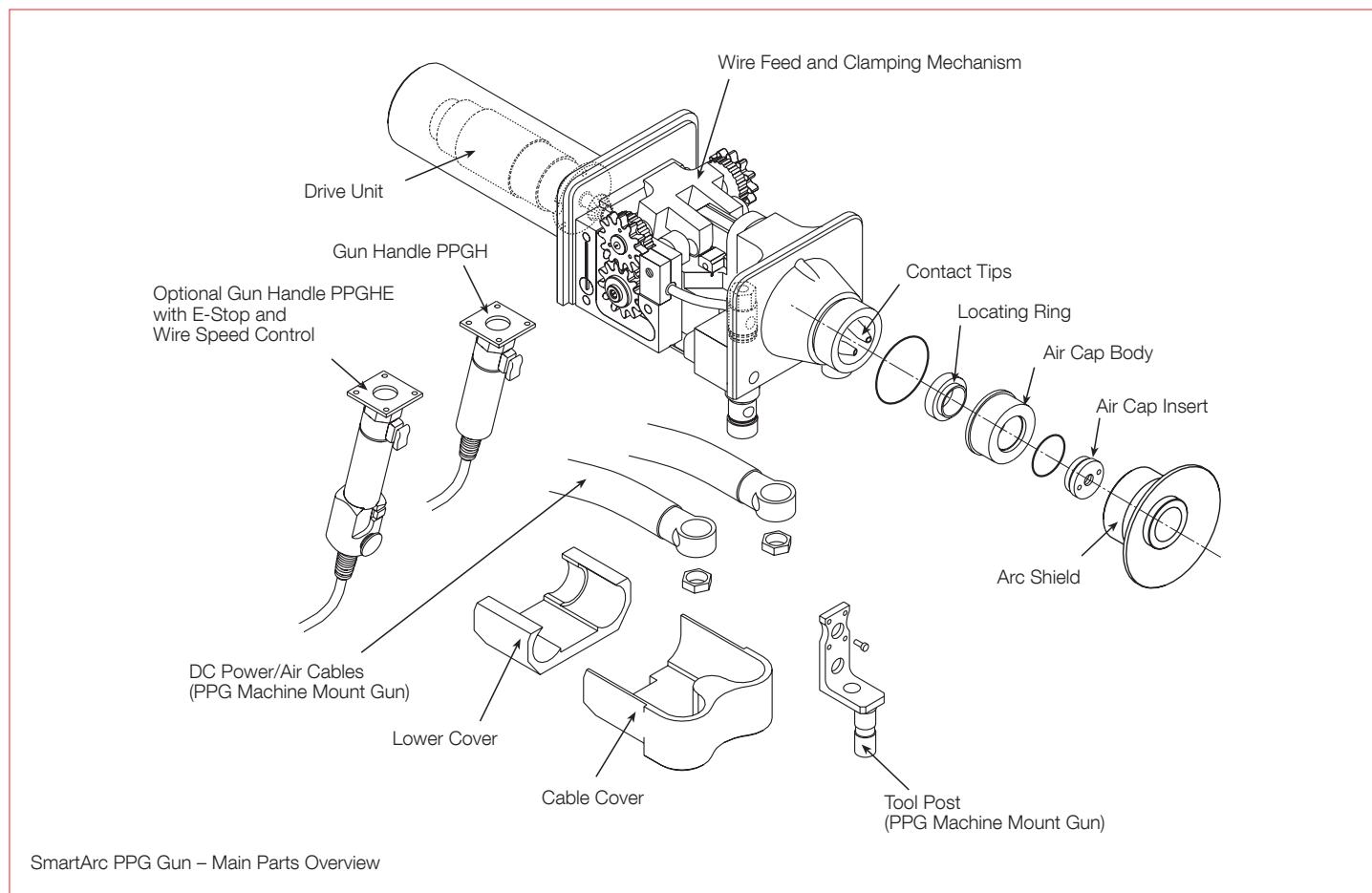

2 Features and Benefits

- Modular design allows for superior flexibility in work configurations.
- Advanced controls deliver outstanding spray process reliability.
- Unique load-sharing control method produces “pushpull” action for smooth and consistent wire feed and allows long distances between the controller and the gun.
- PLC (programmable logic control) automation ensures coating reliability and simple operation.
- Diagnostic system provides ease of use and reliable results.
- Spray hard, soft or cored wires with equal ease (with optional hardware for soft wires).
- High power allows spraying of even the hardest wires quickly.
- Adjustable, air-actuated clamp makes feeding of hard, soft or cored wires far more reliable.
- Voltage measurement at the gun ensures repeatable coating results.
- Low turbulence, near laminar air flow for fast spray rates of very dense, low oxide coatings.
- Fixed position gun contact tips assure consistent, repeatable coatings.
- Quick release wire connector and pull action at the gun allows fast and simple changeover of wire feedstock.
- Machine-mount and hand-held gun options are available for production flexibility.
- Machine-mount guns can easily be mounted on a robot or other gun manipulators for precision and production automation.
- Relocation of the coaxial power cables improves gun balance on hand-held guns.
- Controller, power supply and gun conform to CE standards.
- Optional gun handle incorporates an integrated, system-wide E-stop and wire speed control, on the handle. (Not for sale in CE-conforming countries)

3 Accessories and Options

Oerlikon Metco offers a selection of options and accessories for the SmartArc system and gun for complete operating flexibility. For a complete list of optional parts and spare parts, please refer to the parts lists section of the reference manual.

Power cables, control cable packages, interconnecting extension cables, air supply cables and wire feed cables are available in various lengths to suit specific application needs.

Hardware Kits:

SmartArc systems and guns are factory equipped to spray 1.6 mm (14 gauge) hard wires. Oerlikon Metco has gun hardware options to accommodate different wire materials including:

- 1.6 mm (14 gauge) soft wires
- 1.6 mm (14 gauge) aluminum wires
- 2 mm hard wires
- 2 mm soft wires
- 2 mm aluminum wires
- 2.3 mm (11 gauge) soft wires

Customers may need to change console or gun drive rollers for softer wires. Proper configurations are listed in the SmartArc instruction manual.

Air Caps:

- Fine Spray Air Cap: for smooth coating surfaces (standard-factory equipped)
- Fan Air Cap: for large and wide surface areas
- High Velocity Air Cap: for narrow spray patterns
- High Profile Air Cap: for rough surface finishes
- Focused Air Cap: for narrow spray patterns at higher deposit efficiencies.

Extension Modules:

Extension modules in several lengths are available:

- PPGT-190: 305 mm (1 ft), 90° spray angle
- PPGT-290: 610 mm (2 ft), 90° spray angle

For more information on these extension modules, please refer to the SmartArc PPGT datasheet DSE-0054.

Spool Holders:

The SmartArc comes factory equipped with standard, dorn-style plastic spools holders.

- Wire Baskets: an optional conversion kit is available to for use with wire basket spools

Please note that adapters for hasp-style spools are not available for the SmartArc.

Power Supply Truck:

Using this optional hand truck, the entire SmartArc system (power supply and console) becomes portable. It is an ideal accessory for on-site use and in shops where the system is used in several locations.

4 Technical Data

4.1 Dimensions

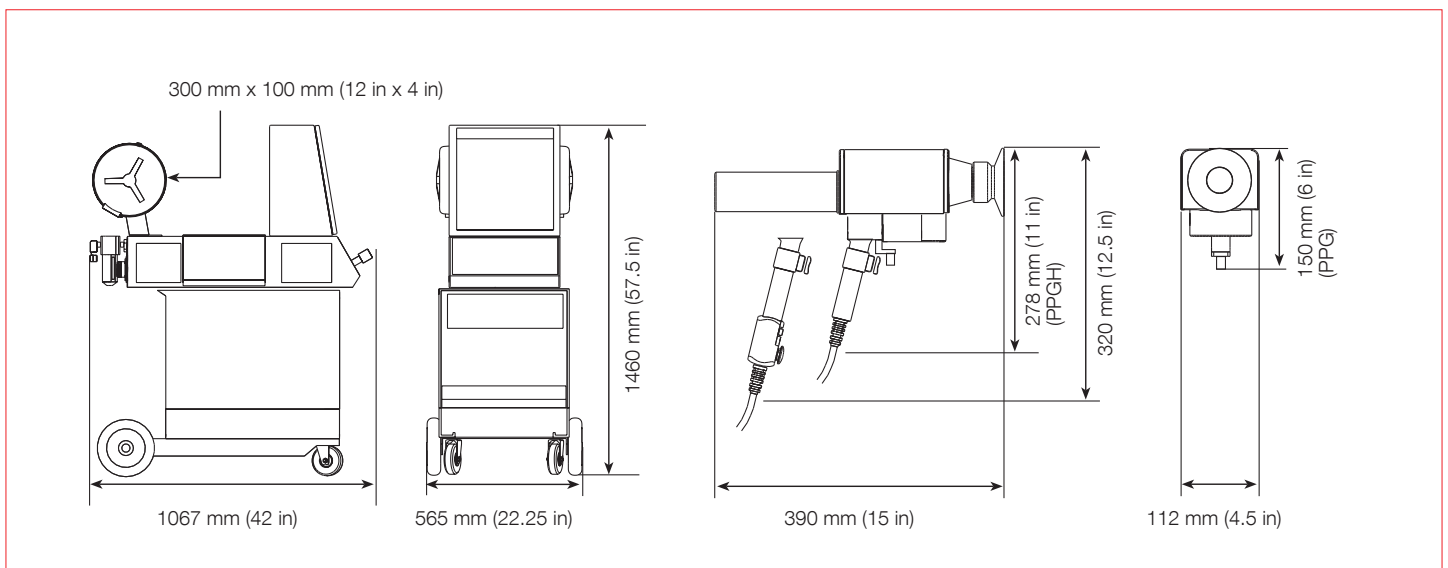

4.2 Specifications

350RU Power Supply

Input Amperage	82 / 72 / 41 / 36 A	
Input Voltage	208 / 230 / 400 / 460 VAC	
Input Frequency	50 / 60 Hz	
Output Voltage	10 to 46 VDC (100 % duty cycle)	
Output Amperage	80 to 400 A (100 % duty cycle)	
Weight	174 kg	383 lb
Maximum ambient temperature	40 °C	104 °F

PPC Console

Air Pressure	2.4 to 4.2 bar	35 to 60 psi
Air Flow	58 to 105 m ³ /h	2200 to 4000 ft ³ /h
Weight	130 kg	290 lb

Gun

Wire Size (hard wires) *	1.6 mm	14 gauge
Models (specify when ordering)	PPG machine-mount, with tool post PPGH hand-held	
Weight PPG	6.3 kg	14 lb
Weight PPGH	5.4 kg	12 lb

* as equipped at factory; options are available or different configurations

CONTACT :

METATECH SDN BHD

T: +603-55199633 E:metatech@metatech.com.my www.metatech.com.my

Information is subject to change without prior notice.